

Stud connector with screw and toothed plate for integrating concrete casting

CTCEM

Article code	Diameter x length (mm)	Weight in Kg each	Price in € each
CTCEM 14/040	14 X 95	0,20	2,90

SPECIFICATIONS

Stud connector with screw and toothed plate for concrete casting integration. Element composed of a \varnothing 14 mm shank of 10.9 hardened steel, with washer and 15 mm hexagonal head. The \varnothing 12 mm threaded body has a truncated conical section at the lower end allowing it to be inserted into the central hole of the 60x50x4 mm stabilizing plate folded on two sides.

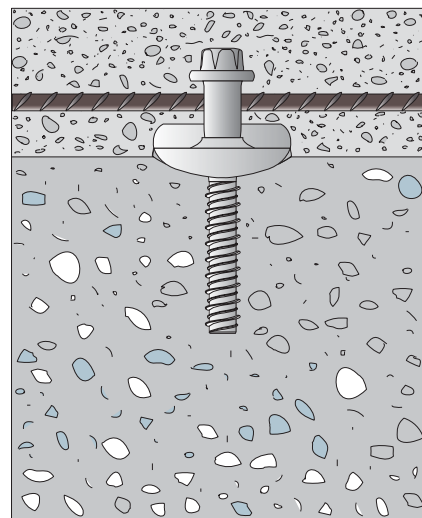

Connector supplied with toothed plate and screw with threaded body, length 65 mm.



1/2" Heavy Duty Electric Impact

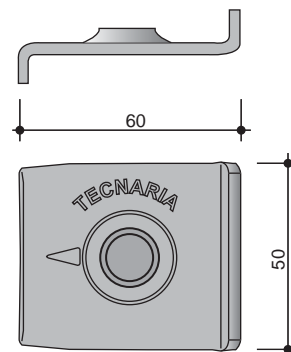
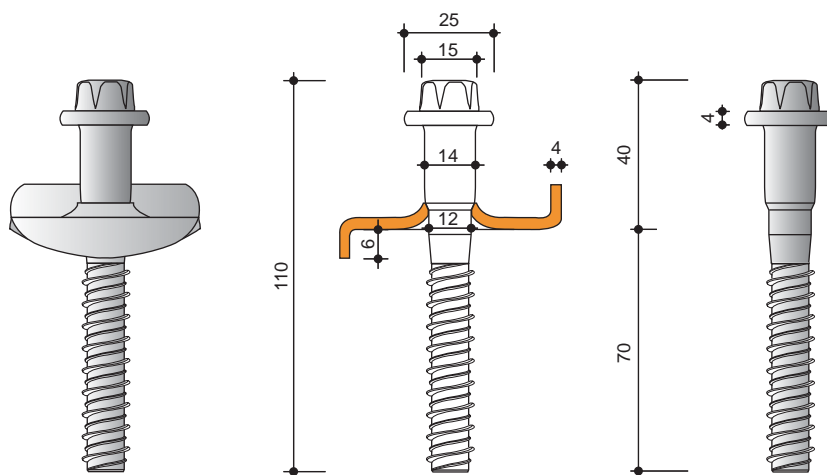

Article code	ACCESSORIES	Price in NET each
ACT-DW292	Heavy Duty Electric Impact Wrench	370,00
PC11160100	Drill bit for concrete \varnothing 11 mm	4,20
ACT-BE15-Q	15 mm hexagonal drive, with 1/2" square fitting	6,30

Price list - validity: 01.01.2018. Replaces the previous ones

TECNARIA®

Viale Pecori Giraldi, 55 - 36061 Bassano del Grappa (VI) - ITALY
www.tecnaria.com - info@tecnaria.com
Tel. + (0)424 502029 r.a. - fax +39 (0)424 502386



Stud connector with screw

for integrating concrete casting

VCEM

Article code	Diameter x lenght (mm)	Weight in Kg each	Price in € each
VCEM 14/035	14 X 95	0,10	1,65

SPECIFICATIONS

Galvanised screw stud connector for concrete casting integration comprising a Ø14 mm shank of 10.9 tempered steel, with 15 mm washer and hexagonal head, and a 60 mm long, Ø 12 mm threaded body, for a total length of 110 mm

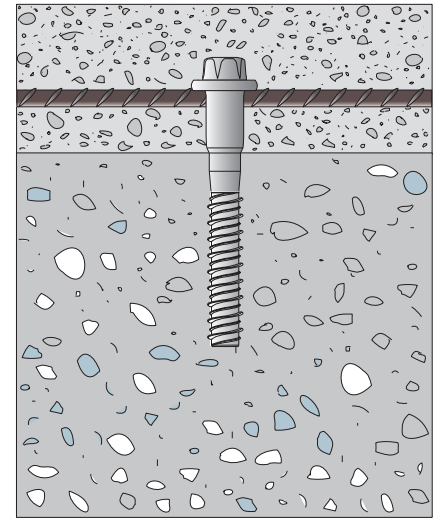

Connector supplied with screw and threaded body, length 65 mm.



1/2" Heavy Duty Electric Impact

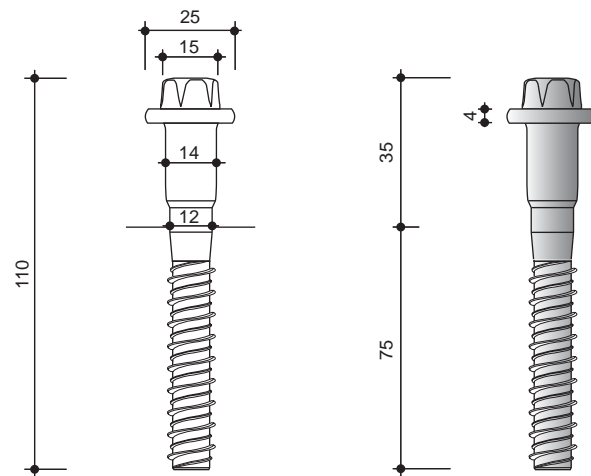

Article code	ACCESSORIES	Price in NET each
ACT-DW292	Heavy Duty Electric Impact Wrench	370,00
PC11160100	Drill bit for concrete Ø 11 mm	4,20
ACT-BE15-Q	15 mm hexagonal drive, with 1/2" square fitting	6,30

Price list - validity: 01.01.2018. Replaces the previous ones

TECNARIA®

Viale Pecori Giraldi, 55 - 36061 Bassano del Grappa (VI) ITALY
 www.tecnaria.com - info@tecnaria.com
 Tel. +39 (0)424 502029 r.a. - fax +39 (0)424 502386



Stud connector with free-spinning washer

for integrating concrete casting
with thin additional slabs or cement mortar

MINI CEM

Article code	Diameter x length (mm)	Weight in Kg each	Price in € each
MINI CEM 10/020	10 X 20	0,06	1,40
MINI CEM 10/030	10 X 30	0,07	1,50

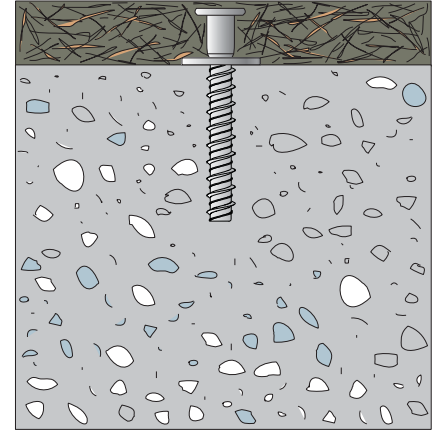

SPECIFICATIONS

Stud connector with galvanised screw for concrete casting integration. Element comprising a shank in hardened steel with \varnothing 10mm, 60 mm threaded body; a \varnothing 10 mm, 20 or 30 mm stud with pre-assembled 3 mm thick free-spinning steel washer 30 mm in diameter; and a 6 mm hexagonal head.



1/2" Heavy Duty Electric Impact

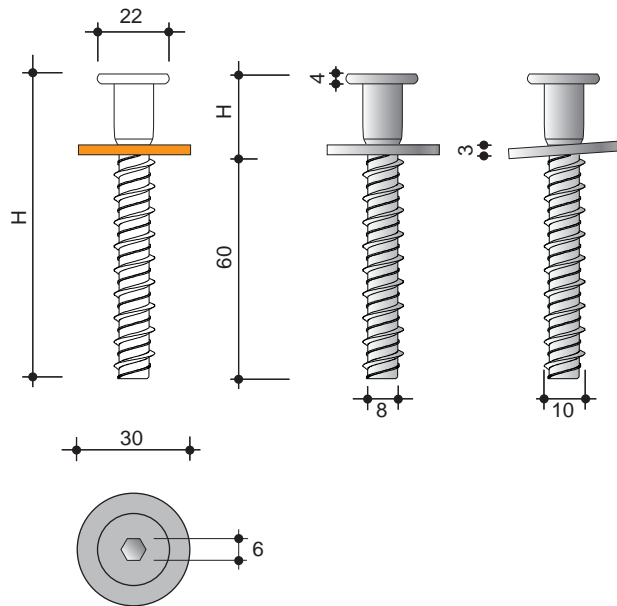

Article code	ACCESSORIES	Price in € NET each
ACT-DW292	Heavy Duty Electric Impact Wrench	370,00
PC080100160	Drill bit for concrete \varnothing 8 mm	4,20
DT7167	15 mm hexagonal drive	4,20

Price list - validity: 01.01.2018. Replaces the previous ones

TECNARIA®

Viale Pecori Giraldi, 55 - 36061 Bassano del Grappa (VI) ITALY
www.tecnaria.com - info@tecnaria.com
Tel. +39 (0)424 502029 r.a. - fax +39 (0)424 502386

